

**KINGS WORTHY, PATH 502
DISUSED RAILWAY LINE ENHANCEMENT
SUNDAY 21ST AUGUST, 2005**



**Worthys
Conservation
Volunteers**



Chosen site for bench in glade.



Excavating holes for the bench legs.



Removing saplings after the bench is complete.



Worthys Conservation Volunteers gather around the new bench.

- Install new oak bench on previously prepared site on the disused railway line.
- Clear site of saplings and sow wildflower seed.
- Picnic lunch.
- Bench made of green-oak measuring 1500x300x150mm (5'x12"x6"), materials provided by Hampshire Paths Partnership.
- 12 volunteers (1 dog), 4 hours.
- Weather hot and sunny, although working in dappled shade.



The completed oak bench, a welcome sight for travellers.



Picnic lunch!

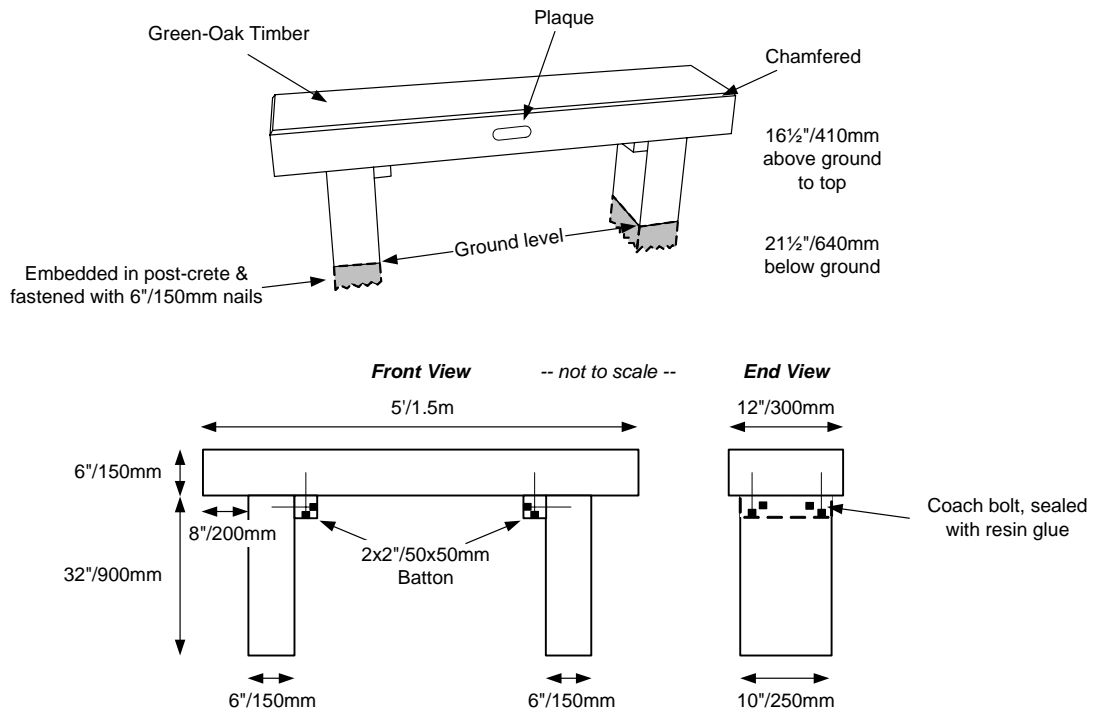

Bench Plan